

Product datasheet

Loadhouse

ASSA ABLOY LH6081L

ASSA ABLOY

ASSA ABLOY Entrance Systems

The global leader in
door opening solutions



Copyright and Disclaimer Notice

Although the contents of this publication have been compiled with the greatest possible care, ASSA ABLOY Entrance Systems cannot accept liability for any damage that might arise from errors or omissions in this publication. We also reserve the right to make appropriate technical modifications/replacements without prior notice.

No rights can be derived from the contents of this document.

Color guides: Color differences may occur due to different printing and publication methods.

No part of this publication may be copied or published by means of scanning, printing, photocopying, microfilm or any other process whatsoever without prior permission in writing by ASSA ABLOY Entrance Systems.

Copyright © ASSA ABLOY Entrance Systems AB 2006-2017.

All rights reserved.

ASSA ABLOY, Besam, Crawford, Albany and Megadoor as words and logo are trademarks belonging to the ASSA ABLOY Group

Technical facts

Features

Sizes - nominal length*	2000, 2450, 3000 mm
Sizes - nominal width*	3300, 3500, 3600 mm
Insulated cladding: Thickness of insulation:	Roof and wall panels with 40 mm insulation
Surface treatment:	Hot dip galvanised Inside colour-coated Outside colour coated 25 µm
Uninsulated cladding: Thickness of material:	0,63 mm profiled steel sheet
Surface treatment:	Hot dip galvanised Inside protective coating 10 µm Outside colour-coating 25 µm
Surface steel frame:	Hot dip galvanised

* Other sizes are available on request

Performance

Basic windload	0,65 kN/m ²	Eurocode 3
Basic snow load	0,89 kN/m ²	Eurocode 3
Accumulated snow load	1,78 kN/m ²	Eurocode 3

Observe the local building regulations

Contents

Copyright and Disclaimer Notice	2
Technical facts	3
Contents	4
1. Description	5
1.1 General	5
1.1.1 Application	5
1.1.2 Advantages	5
1.1.3 Overview	5
1.1.4 Standard	5
1.1.5 Options	5
1.1.6 Model HM - House mechanical	6
1.1.7 Model HI - House inflatable	6
1.2 Cladding types	7
1.2.1 I - Insulated	7
1.2.2 U - Uninsulated	7
1.2.3 X - Steel frame	7
1.3 Options	8
1.3.1 Angular adjustment	8
1.3.2 Drain pipe and gutter	8
1.3.3 Anti-drip-coating (only for cladding type U - uninsulated)	8
1.3.4 Wall profile and water nose	8
1.3.5 Protrusion on façade	9
1.3.6 Wall protection plywood veneer	9
2. Specifications	10
2.1 Dimensions HM	10
2.2 Shelter selection guide HM	10
2.3 Dimensions HI	11
3. Building and space requirements	12
3.1 Wall fixings	12
3.1.1 Fixing heights	12
3.2 Connection to the building	13
3.2.1 Maximum wall fixing force (kN)	13
3.2.2 Wall set up building	13
4. Service	14
Index	15

1. Description

1.1 General

1.1.1 Application

The ASSA ABLOY LH6081L light version stand alone loadhouse is a loading system that represents a complete and stand-alone unit that is installed in front of the building. It comprises all components of a docking system: an Autodock leveler, a dock shelter and an overhead sectional door. These components are presented in their individual product datasheets. This product datasheet describes the steel cladding; the loadhouse in which all components are integrated.

Since it is installed outside the building directly in front of the door opening it has great advantages over a conventional internal ramp for both new buildings as well as for existing buildings that are to be upgraded without any major modifications to the construction of the building. As a standard the entire steel frame construction of the ASSA ABLOY LH6081L light version stand alone loadhouse is hot dip galvanised. Recommended options are a roof drainage system and flashing, adapted to your building.

1.1.2 Advantages

- Thermal separation of warehouse and docking system guarantees considerable energy saving, important for temperature controlled and freezer warehouses.
- Easy and fast installation of pre-assembled components on existing foundations which can be fastened on the outside wall of the building, without disrupting the daily use of the building.
- The cladding consists either of non-insulated profile sheet material or of 40 mm insulation panels; it can also be cladded with the material of the warehouse facade.
- The ASSA ABLOY LH6081L light version stand alone loadhouse design allows the use of an Autodock swinglip or telescopic lip leveler and the installation of a mechanical or inflatable dock shelter, whatever best suits the loading frequency.
- Because of individual components it can be installed as a single house or a multiple system.
- The single house can be installed at a 45° or 135° angle if the room in front of the loading system is limited.
- The storage room in the warehouse is extended since the complete docking system is placed outside the building.
- Even shorter tax depreciation periods are possible. Please ask your tax lawyer.

1.1.3 Overview

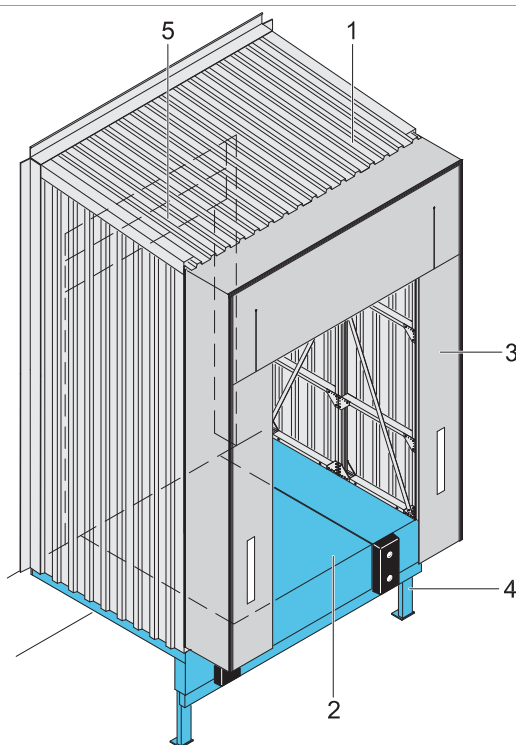

- 1) Steel cladding
- 2) Autodock leveler
- 3) Dock shelter
- 4) Autodock support structure
- 5) Overhead sectional door

1.1.4 Standard

Nominal length:	2000, 2450, 3000 mm
Nominal width:	3300, 3500, 3600 mm
Angular adjustment:	90°

1.1.5 Options

Models:	HM - house mechanical HI - house inflatable
Cladding types:	I - insulated U - uninsulated X - steel frame
Angular adjustments:	45° or 135°
Roof:	Drain pipe and gutter Anti-drip-coating
Wall:	Wall connection profile Wall protection plywood veneer

1.1.6 Model HM - House mechanical

The model HM is designed for an Autodock leveler with a mechanical dock shelter type SME or SMP. This loadhouse model is the most economical solution for external dock installations.

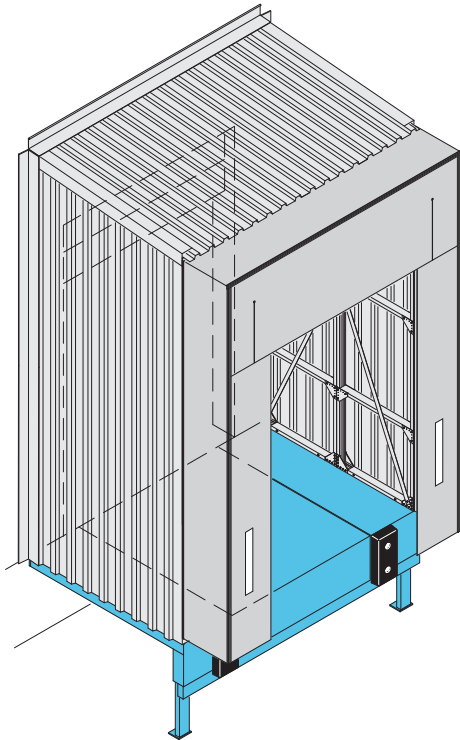

1.1.7 Model HI - House inflatable

The model HI is designed for an Autodock leveler with an inflatable dock shelter type SIR or SIB. This loadhouse model provides a high degree of sealing.

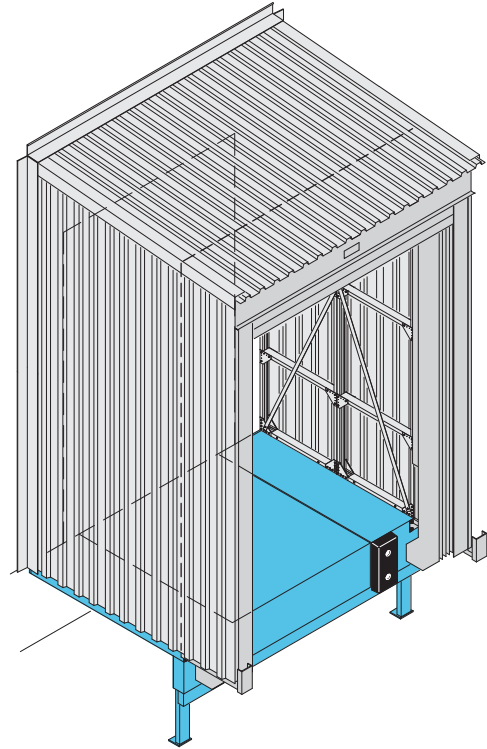

1.2 Cladding types

1.2.1 I - Insulated

For optimal insulation the I-insulated type is provided with 40 mm insulated cladding.

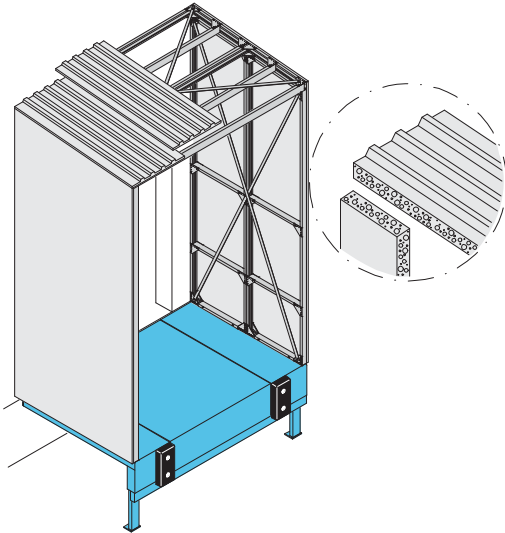

1.2.3 X - Steel frame

For applications where the existing building facade cladding is used, the X-steel frame type is provided with only a steel frame.

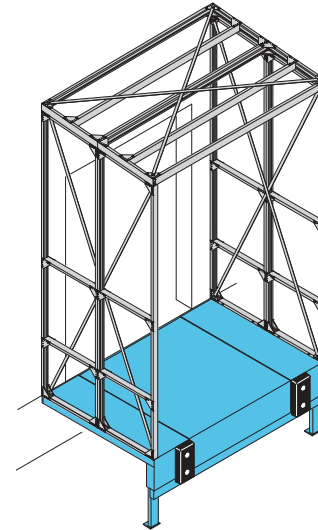

1.2.2 U - Uninsulated

The U-uninsulated type is provided with non-insulated profile sheet material cladding.

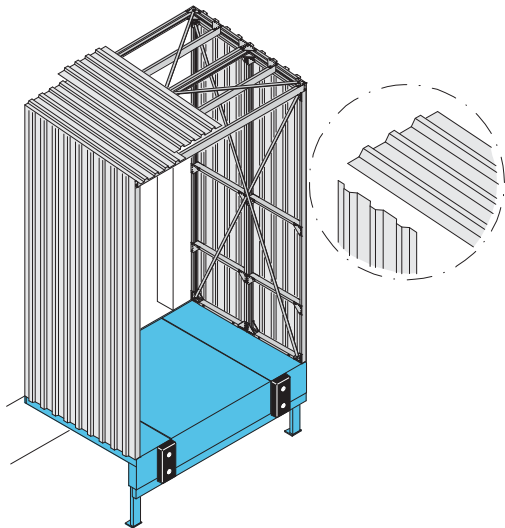

1.3 Options

1.3.1 Angular adjustment

For applications where the yard space is limited, the loadhouse can be installed with angular adjustments.

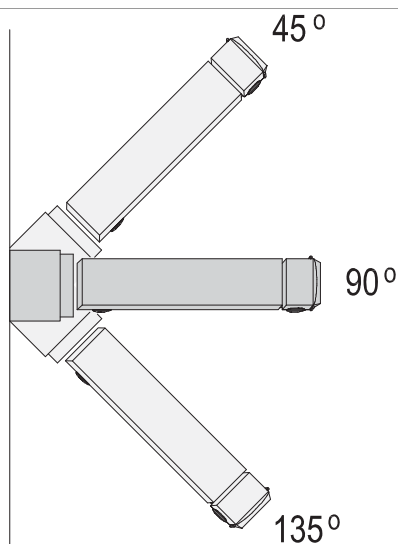

1.3.2 Drain pipe and gutter

To have controlled water drainage, the loadhouse can be equipped with drain pipe and gutter.

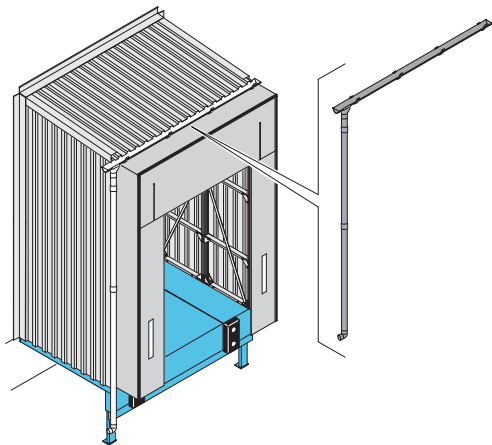

1.3.3 Anti-drip-coating (only for cladding type U - uninsulated)

To avoid condense water leading to moisture in the loading area, the inside surface of the roof sheet material can be delivered with a layer of felt as anti-drip-coating.

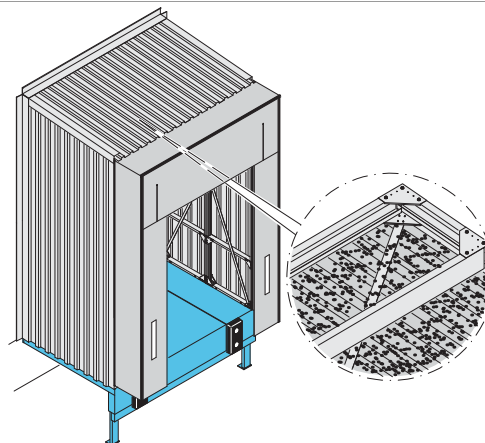

1.3.4 Wall profile and water nose

To connect the loadhouse structure to the building, horizontal angle profiles including sealing material can be included in the installation.

Water is led off the loadhouse by a water hose on the side.

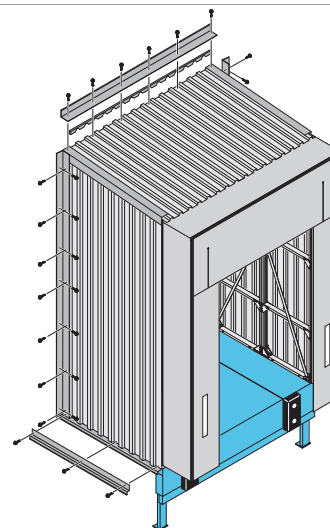

1.3.5 Protrusion on façade

In order to meet all kind of façades a protrusion on the façade of +100mm to -100mm is available.

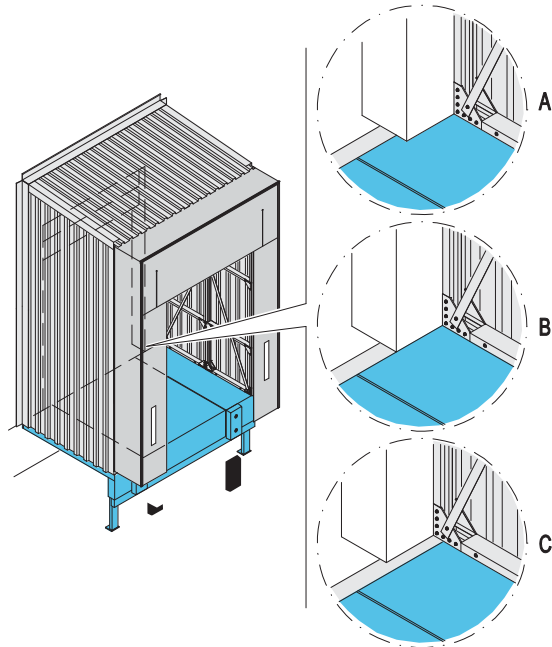

- a) Positive protrusion
- b) No protrusion
- c) Negative protrusion

1.3.6 Wall protection plywood veneer

To protect the walls inside the loadhouse against possible damages from the handling equipment, the lower part can be equipped with a cover of a plywood veneer (2500 mm high). This is also the recommended solution for applications where the inside walls needs to be closed and have a straight surface.

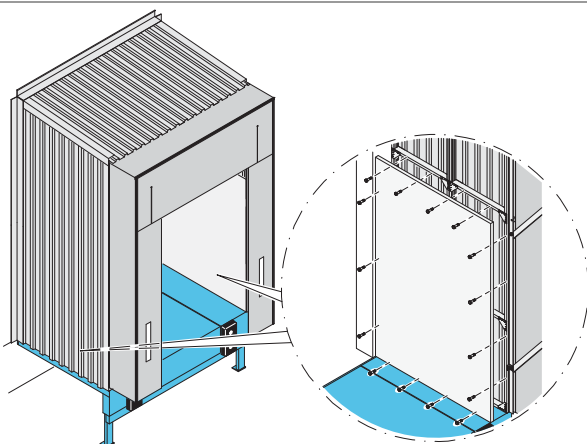

2. Specifications

2.1 Dimensions HM

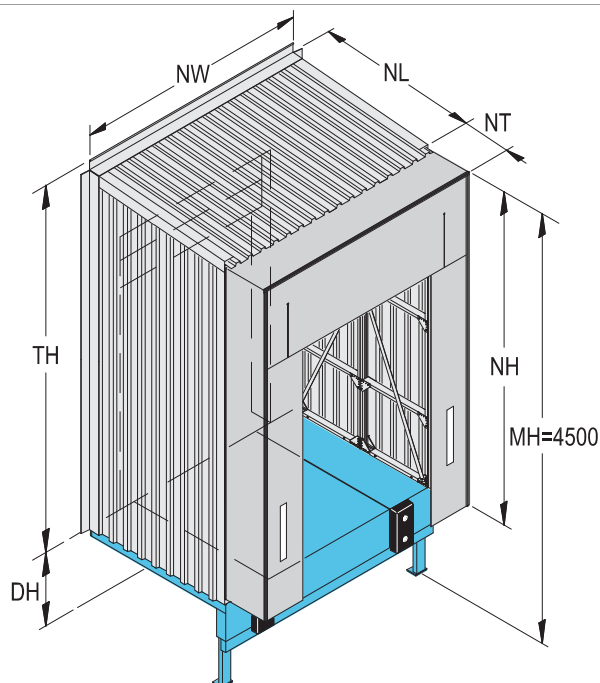

NW	Nominal width [3300, 3500, 3600 mm]
NL	Nominal length
TH	Total height
DH	Dock height
NH	Nominal height dock shelter
NT	Nominal width dock shelter
MH	Assembly height dock shelter Recommendation: MH = 4500 for lorry-heights up to 4000 mm

		Total Height > TH*		
		NL 2000	NL 2450	NL 3000
DH	950	3845	3875	3925
	1000	3795	3825	3875
	1050	3745	3775	3825
	1100	3695	3725	3775
	1150	3645	3675	3725
	1200	3595	3625	3675
	1250	3545	3575	3625
	1300	3495	3525	3575
	1350	3445	3475	3525
	1400	3395	3425	3475
1450	3345	3375	3425	
1500	3295	3325	3375	

* Measurement only valid for insulated wall setup.

For uninsulated wall setup TH is 60mm less.

For steel frame wall setup TH is 180mm less.

When the loadhouse is supplied with rain pipe and gutter add 100mm.

2.2 Shelter selection guide HM

Depending on the installation type (single or multi) and the width of the loadhouse, the right selection of the type of mechanical shelter & nominal width is indicated in this table.

HM type	HM width	SMP NW 3200	SME/SMP NW 3250	SMP NW 3400	SME/SMP NW 3450	SMP NW 3500
Multi	3300	■				
Single	3300		■			
Multi	3500			■		
Single	3500				■	
Multi	3600					■
Single	3600					■

2.3 Dimensions HI

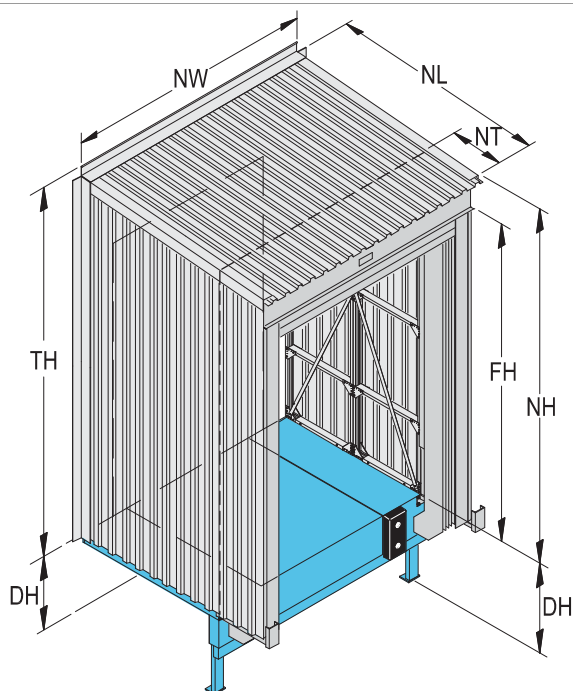

NW	Nominal width [3600 mm]			
NL	Nominal length			
TH	Total height			
DH	Dock height			
NH	Nominal height dock shelter			
NT	Nominal width dock shelter			
FH	Free height above finish floor level			
Total Height -> TH*				
NH	FH	NL 2000	NL 2450	NL 3000
3555	3100	3875	3905	3955
3755	3300	4075	4105	4155
4055	3600	4375	4405	4455
4355	3900	4675	4705	4755

* Measurement only valid for insulated wall setup.

For uninsulated wall setup TH is 60mm less.

For steel frame wall setup TH is 180mm less.

3. Building and space requirements

3.1 Wall fixings

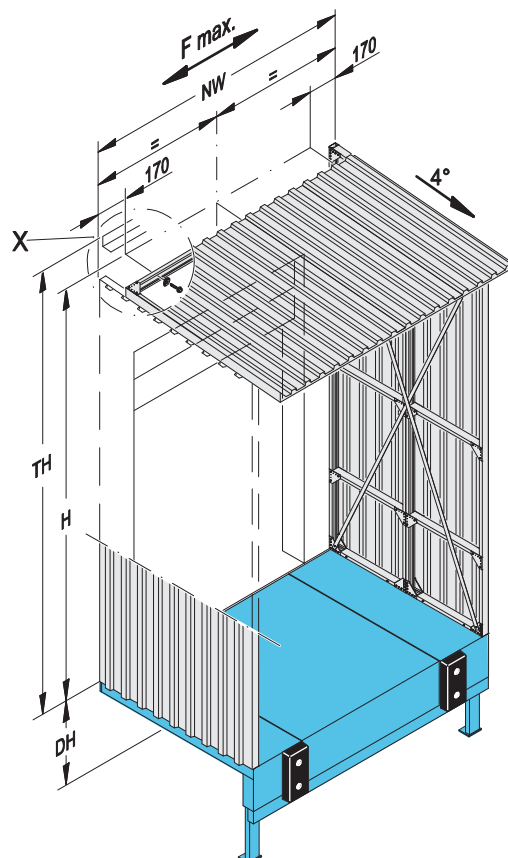

F_{max} = Maximum wall fixing force (kN)

H = Fixing height (min. 100 mm above door height)

3.1.1 Fixing heights

I - Insulated

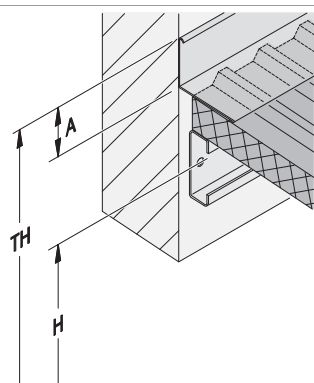

$$H = TH - 255 \text{ mm}$$

$$A = 100 \text{ mm}$$

U - Noninsulated

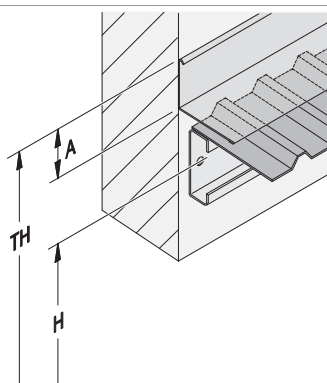

$$H = TH - 195 \text{ mm}$$

$$A = 100 \text{ mm}$$

X - Steelframe

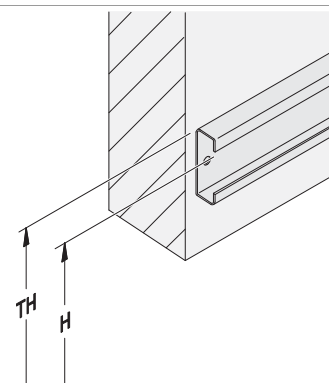

$$H = TH - 75 \text{ mm}$$

3.2 Connection to the building

3.2.1 Maximum wall fixing force (kN)

NL	F max.
2000 mm	4,9 kN
2450 mm	4,9 kN
3000 mm	5,9 kN

3.2.2 Wall set up building

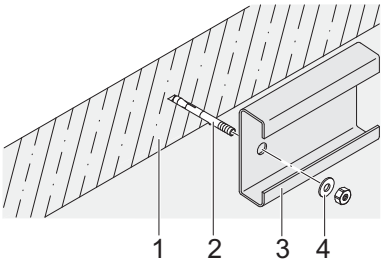
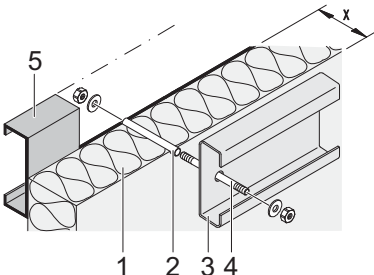
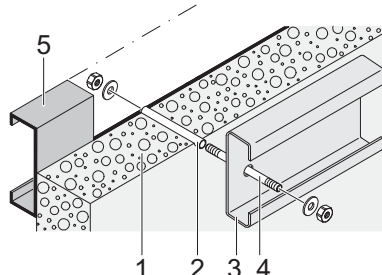
Concrete wall	Insulated wall	Light concrete wall
		
<ol style="list-style-type: none"> 1) Concrete wall 2) Dowel 3) Roof profile 4) Washer 	<ol style="list-style-type: none"> 1) Insulated wall 2) Spacer tube 3) Roof profile 4) Threaded bolt with nut and washer 5) Mounting frame * X) Wall thickness (x=100 or 120 mm) 	<ol style="list-style-type: none"> 1) Light concrete wall 2) Spacer tube 3) Roof profile 4) Threaded bolt with nut and washer 5) Mounting frame*

*(eg. c-profile 120x40x15x3 mm)

4. Service

Preventive Maintenance Program and Modernization Services

As your entrances are part of your business flow, there's every reason to keep them working well. ASSA ABLOY Entrance Systems offers you a maintenance and modernization expertise to rely on. Our Maintenance Programs and Modernization Services are backed by a extensive expertise for all types of industrial door and docking systems, independent of brand. At your disposal is a team of dedicated expert technicians, proven through decades of maintenance, service and satisfied customers.

Preventive Maintenance Programs

Minimizing lost time, lost energy and unexpected hassle is our team's constant objective. Our service organization can support you 24/7 in maintaining all industrial door and docking systems, independent of brand. If you want to be one step ahead of break-downs, explore our portfolio of Pro-Active Care plans. Naturally, we also offer entrance upgrades to suit your specific wishes and business needs.

Pro-Active Care - Maintenance plans to fit your business

Regular maintenance can extend the lifetime of your equipment and help prevent unexpected problems. Our technician arrives on-site equipped with the knowledge and tools to service all automatic entrances, independent of brand.

- **Pro-Active Bronze**

The base on which all Pro-Active Plans are built provides the security of knowing that your equipment is regularly inspected and certified for safety, as well as performing optimally. It includes a number of planned on-site visits depending on your needs. Any unplanned service calls required during the term of the contract (including labor, travel and parts) are billed at special Pro-Active Care prices.

- **Pro-Active Silver**

This plan provides all the benefits of Pro-Active Bronze with the added advantage of labor and travel being included for service calls during regular business hours. The only additional charge would be for any parts that may be needed throughout the term of the contract.

- **Pro-Active Gold**

This plan provides the ultimate protection for your automatic entrance investment. It includes all the benefits of Pro-Active Silver, plus replacement of any parts required during an unplanned repair or planned maintenance visit. Pro-Active Gold is an excellent way to budget your automatic door expenses annually.

- **Pro-Active Tailor-Flex**

Our most flexible maintenance and service offering. The Pro-Active Care plan is designed by you, our customer. The plan allows you to balance your maintenance expenses against your real-world budget and presents the option to add or delete a number of maintenance elements to suit your budget goals, while meeting your overall performance and safety needs.

Modernization

Your entrances are a long-term investment, from which you always want the best. Products develop over time, so do regulations and your business. Let us help you increase energy savings and meet today's standards. We provide advice and modernization kits for outdated installations, ensuring your investment meet requirements and performs optimally for many more years to come.

Re-Active Service		Pro-Active Care				
		Pro-Active Bronze	Pro-Active Silver	Pro-Active Gold	Pro-Active Tailor Flex	
		○	○	○	●	Other customized requests such as Response Time, Performance InfoPack and Advanced User Training
		○	○	●	○	Replacement of worn parts according to preventive Consumable Exchange Program
		○	○	●	○	Replacement of spare parts on breakdowns
		○	●	●	○	Travel and labor for additional call-out visits
		●	●	●	●	Preventive maintenance visits 1-4 times per year
		●	●	●	●	Travel and labor for preventive maintenance visits
		●	●	●	●	Response time and priority on call-outs <24h
		●	●	●	●	Preventive planned maintenance that meets the most demanding standards in the market
	●	●	●	●	●	Safety and quality checks according to applicable regulations and norms. Documentation of test results provided
●	●	●	●	●	●	Documentation of equipment status, assessment and service provided, all generated on site
●	●	●	●	●	●	Highly trained professional technicians with extensive knowledge, state-of-the-art tools and the right spare parts*
●	●	●	●	●	●	Dedicated Professional Customer Care Hotline

● = Included as standard
○ = Available at special prices

* Well-stocked service vehicles with genuine and new spare parts

Index

A	
Advantages	5
Angular adjustment	8
Anti-drip-coating (only for cladding type U - uninsulated)	8
Application	5
B	
Building and space requirements ...	12
C	
Cladding types	7
Connection to the building	13
Copyright and Disclaimer Notice	2
D	
Description	5
Dimensions HI	11
Dimensions HM	10
Drain pipe and gutter	8
F	
Features	3
Fixing heights	12
G	
General	5
I	
I - Insulated	7
M	
Maximum wall fixing force (kN)	13
Model HI - House inflatable	6
Model HM - House mechanical	6
O	
Options	5, 8
Overview	5
P	
Performance	3
Protrusion on façade	9
S	
Service	14
Shelter selection guide HM	10
Specifications	10
Standard	5
T	
Technical facts	3
U	
U - Uninsulated	7
W	
Wall fixings	12
Wall profile and water nose	8
Wall protection plywood veneer	9
Wall set up building	13
X	
X - Steel frame	7

ASSA ABLOY Entrance Systems is a leading supplier of entrance automation solutions for the efficient flow of goods and people. Building on the long-term success of the Besam, Crawford, Albany and Megadoor brands, we offer our solutions under the ASSA ABLOY brand. Our products and services are dedicated to satisfying end-user needs for safe, secure, convenient and sustainable operations.

ASSA ABLOY Entrance Systems is a division of ASSA ABLOY.

assaabloyentrance.com



ASSA ABLOY Entrance Systems

assaabloyentrance.com